

technical
parameters

NEO·T

Toggle Clamp
Injection Molding Machine

Tederic Machinery Co., Ltd.
No.245 Wenzhe North Road,
Hangzhou City, Zhejiang Province, 310018, China
T. +86-571-86733387
www.tedericglobal.com

t.NEO-T.202205.03

tederic
SMART INJECTION

NEO-T

Parameters

Clamping unit	Unit	NEO-T90		
Clamping force	kN	900		
Clamping stroke	mm	340		
Space between tie bars	mm	360×360		
Max. mold height	mm	390		
Min. mold height	mm	150		
Ejector stroke	mm	120		
Ejector force	kN	34		
No. of ejector pins	piece	5		
Max. daylight	mm	730		
Min. mold dimension	mm	252x252		
Platen dimensions (HxV)	mm	530x530		
Injection unit	Unit	i380		
		A	B	C
Screw diameter	mm	35	38	42
Screw L/D ratio	L/D	21.7	20.0	18.1
Shot size (theoretical)	cm ³	168	199	243
Injection weight (PS)	g	153	181	221
Injection pressure	MPa	228.0	193.0	158.0
Injection rate into air	g/s	106	125	153
Screw speed	rpm	250		
Max. injection speed	mm/s	121		
Injection stroke	mm	175		
Others	Unit	i380		
Max. pump pressure	MPa	17.5		
Pump motor power	kW	16		
Heater power	kW	6.6		
Hopper capacity	kg	25		
Oil tank volume	L	120		
Total machine weight	t	3.5		
Machine dimension (LxWxH)	m	4.34x1.3x2.0		

Remarks:
 The bearing weight by moving platen is 2/3 of the maximum mold weight.
 Theoretical capacity is the calculated volume of injection produced by the cross-sectional area of the screw/plunger and the injection stroke
 The injection weight (PS) is the theoretical value derived from the injection volume and the typical melt density of polystyrene
 The screw speed is the theoretical maximum screw speed.
 Please inform us if you have requirement for engineering material like PVC, PMMA or some special requirement.

Due to continuous improvements, we reserve the right to modify any aspect of the specification without prior notice.

Front view of machine dimension

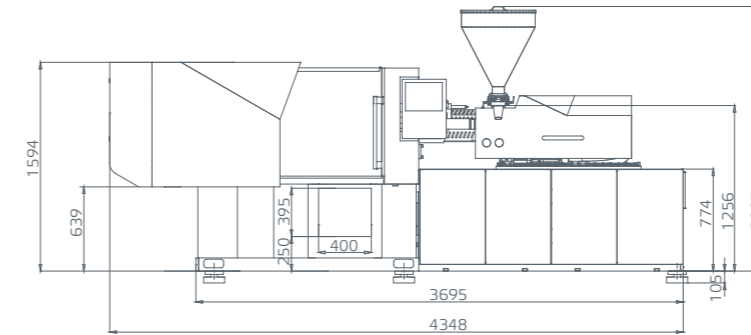

Top view of machine dimension

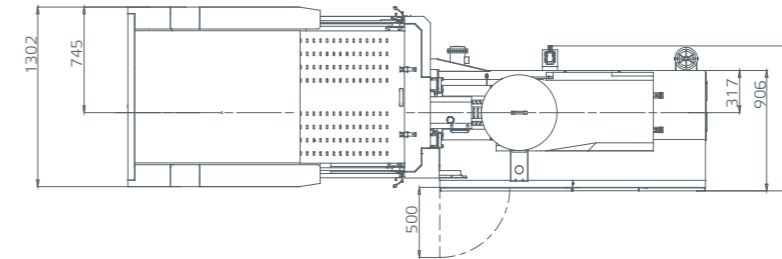

Moving platen dimension

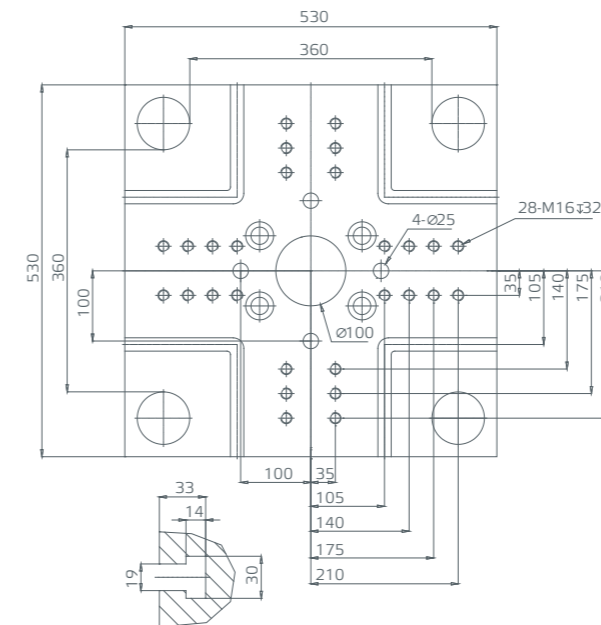

Unit:mm

Robot installation dimension

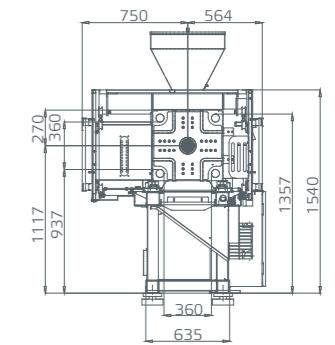

Robot fixed platen dimension

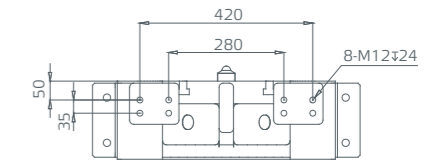

Feeding port dimensions

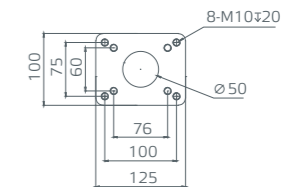

Clamping unit

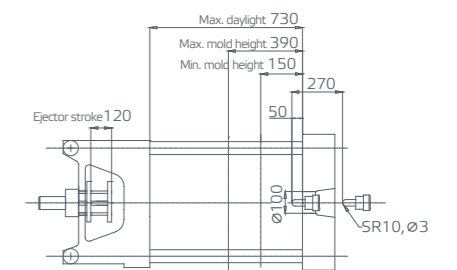

NEO-T

Parameters

Clamping unit		NEO-T120		
Clamping force	kN	1200		
Clamping stroke	mm	360		
Space between tie bars	mm	410×410		
Max. mold height	mm	450		
Min. mold height	mm	150		
Ejector stroke	mm	120		
Ejector force	kN	34		
No. of ejector pins	piece	5		
Max. daylight	mm	810		
Min. mold dimension	mm	287×287		
Platen dimensions (HxV)	mm	610×610		
Injection unit		i510		
	Unit	A	B	C
Screw diameter	mm	38	42	45
Screw L/D ratio	L/D	22.1	20.0	18.7
Shot size (theoretical)	cm ³	222	270	310
Injection weight (PS)	g	202	246	282
Injection pressure	MPa	233.0	190.0	166.0
Injection rate into air	g/s	130	159	182
Screw speed	rpm	250		
Max. injection speed	mm/s	126		
Injection stroke	mm	195		
Others		i510		
Max. pump pressure	MPa	17.5		
Pump motor power	kW	20		
Heater power	kW	9.5		
Hopper capacity	kg	25		
Oil tank volume	L	160		
Total machine weight	t	4.4		
Machine dimension (LxWxH)	m	4.66x1.45x2.07		

Remarks:

The bearing weight by moving platen is 2/3 of the maximum mold weight.

Theoretical capacity is the calculated volume of injection produced by the cross-sectional area of the screw/plunger and the injection stroke

The injection weight (PS) is the theoretical value derived from the injection volume and the typical melt density of polystyrene

The screw speed is the theoretical maximum screw speed.

Please inform us if you have requirement for engineering material like PVC, PMMA or some special requirement.

Due to continuous improvements, we reserve the right to modify any aspect of the specification without prior notice.

Front view of machine dimension

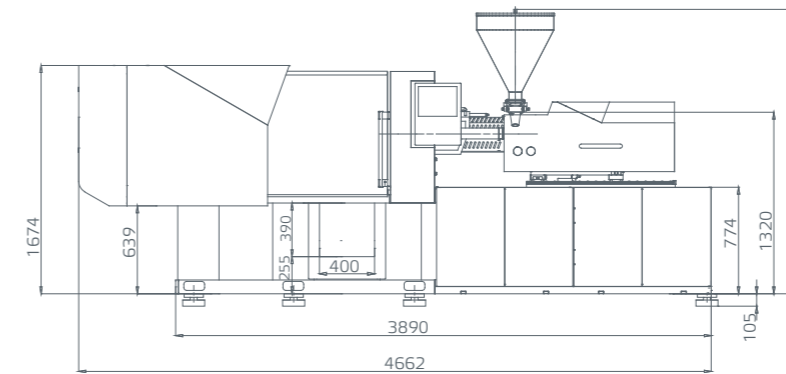

Top view of machine dimension

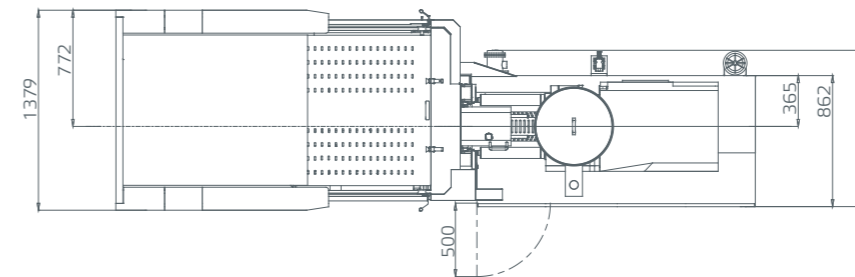

Moving platen dimension

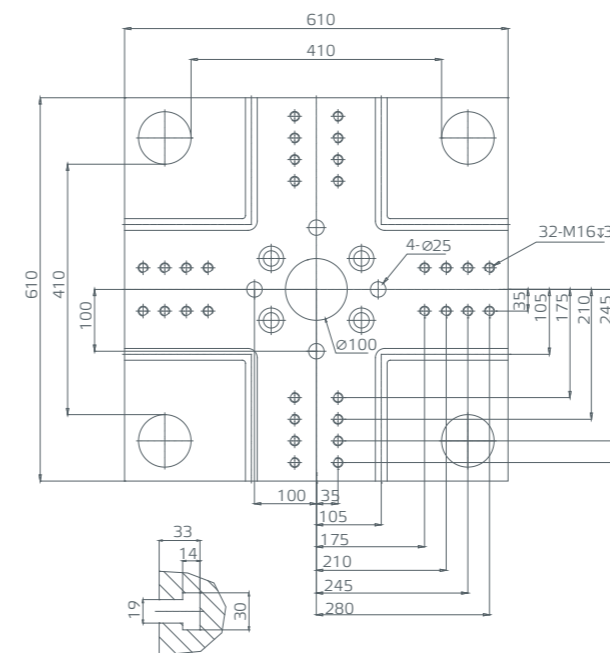

Robot installation dimension

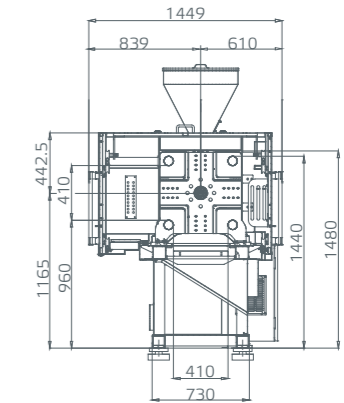

Robot fixed platen dimension

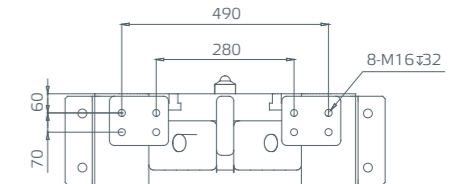

Feeding port dimensions

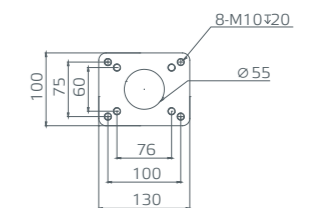

Clamping unit

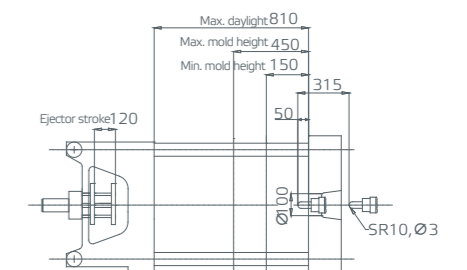

Unit:mm

NEO-T

Parameters

Clamping unit		NEO-T160		
Clamping force	kN	1600		
Clamping stroke	mm	450		
Space between tie bars	mm	470×470		
Max. mold height	mm	530		
Min. mold height	mm	180		
Ejector stroke	mm	150		
Ejector force	kN	49		
No. of ejector pins	piece	5		
Max. daylight	mm	980		
Min. mold dimension	mm	329×329		
Platen dimensions (HxV)	mm	700×700		
Injection unit		i600		
Screw diameter	mm	A	B	C
Screw L/D ratio	L/D	21.4	20.0	18.0
Shot size (theoretical)	cm ³	312	358	442
Injection weight (PS)	g	284	326	402
Injection pressure	MPa	223.5	194.7	157.7
Injection rate into air	g/s	135	155	192
Screw speed	rpm	238		
Max. injection speed	mm/s	107		
Injection stroke	mm	225		
Others		i600		
Max. pump pressure	MPa	17.5		
Pump motor power	kW	20		
Heater power	kW	10.4		
Hopper capacity	kg	50		
Oil tank volume	L	190		
Total machine weight	t	5.4		
Machine dimension (LxWxH)	m	4.98x1.37x2.11		

Remarks:
 The bearing weight by moving platen is 2/3 of the maximum mold weight.
 Theoretical capacity is the calculated volume of injection produced by the cross-sectional area of the screw/plunger and the injection stroke
 The injection weight (PS) is the theoretical value derived from the injection volume and the typical melt density of polystyrene
 The screw speed is the theoretical maximum screw speed.
 Please inform us if you have requirement for engineering material like PVC, PMMA or some special requirement.

Due to continuous improvements, we reserve the right to modify any aspect of the specification without prior notice.

Front view of machine dimension

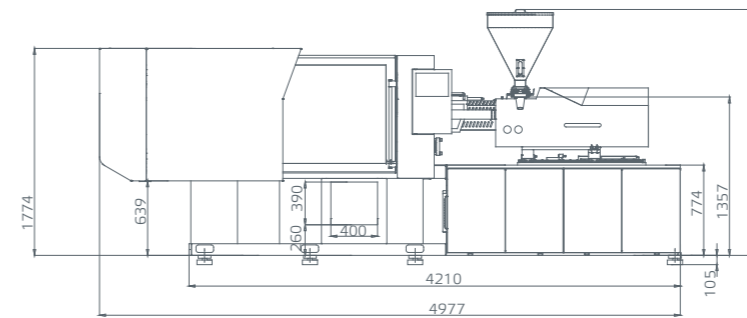

Top view of machine dimension

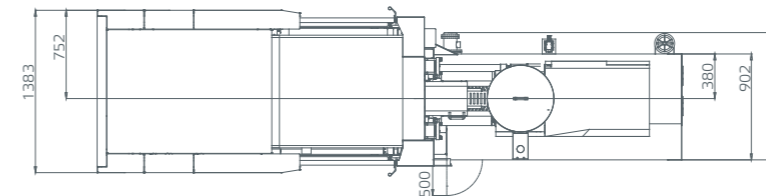

Moving platen dimension

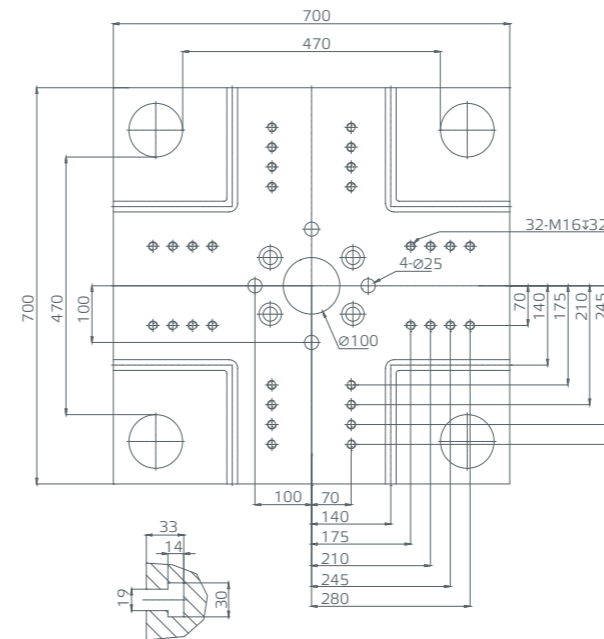

Robot installation dimension

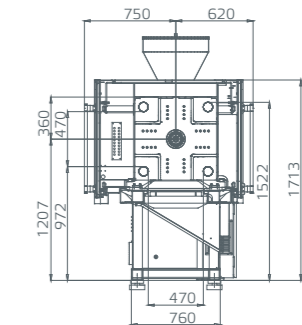

Robot fixed platen dimension

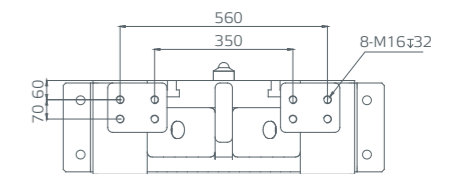

Feeding port dimensions

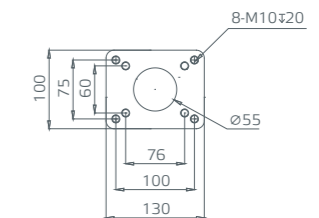

Clamping unit

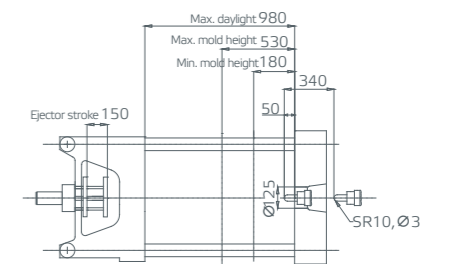

Unit:mm

NEO-T

Parameters

Clamping unit		NEO-T200		
Clamping force	kN	2000		
Clamping stroke	mm	510		
Space between tie bars	mm	530×530		
Max. mold height	mm	560		
Min. mold height	mm	200		
Ejector stroke	mm	150		
Ejector force	kN	67		
No. of ejector pins	piece	9		
Max. daylight	mm	1070		
Min. mold dimension	mm	371×371		
Platen dimensions (HxV)	mm	800×800		
Injection unit		i850		
Screw diameter	mm	A	B	C
Screw L/D ratio	L/D	45	50	55
Shot size (theoretical)	cm ³	22.2	20.0	18.2
Injection weight (PS)	g	374	461	558
Injection pressure	MPa	340	420	508
Injection rate into air	g/s	229.9	186.2	153.9
Screw speed	rpm	164	203	246
Max. injection speed	mm/s	230		
Injection stroke	mm	114		
Others		i850		
Max. pump pressure	MPa	235		
Pump motor power	kW	17.5		
Heater power	kW	25		
Hopper capacity	kg	13.0		
Oil tank volume	L	50		
Total machine weight	t	210		
Machine dimension (LxWxH)	m	6.9		
		5.26x1.68x2.17		

Remarks:

The bearing weight by moving platen is 2/3 of the maximum mold weight.

Theoretical capacity is the calculated volume of injection produced by the cross-sectional area of the screw/plunger and the injection stroke

The injection weight (PS) is the theoretical value derived from the injection volume and the typical melt density of polystyrene

The screw speed is the theoretical maximum screw speed.

Please inform us if you have requirement for engineering material like PVC, PMMA or some special requirement.

Due to continuous improvements, we reserve the right to modify any aspect of the specification without prior notice.

Front view of machine dimension

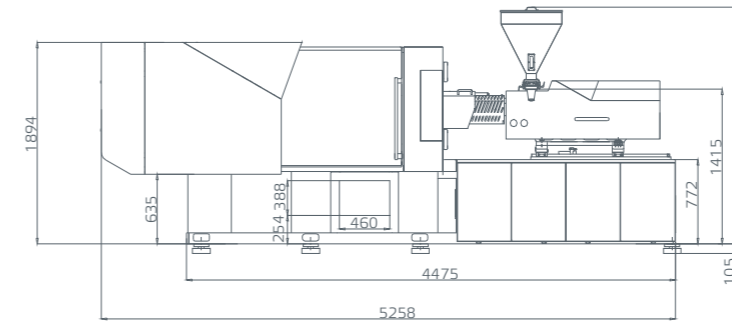

Top view of machine dimension

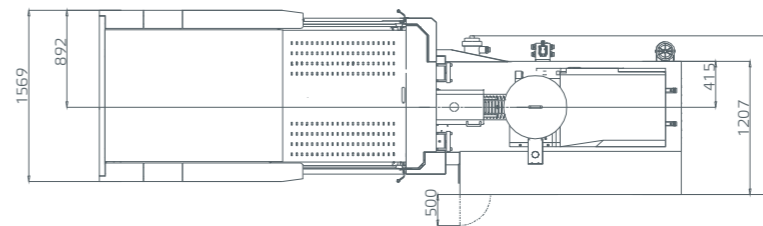

Moving platen dimension

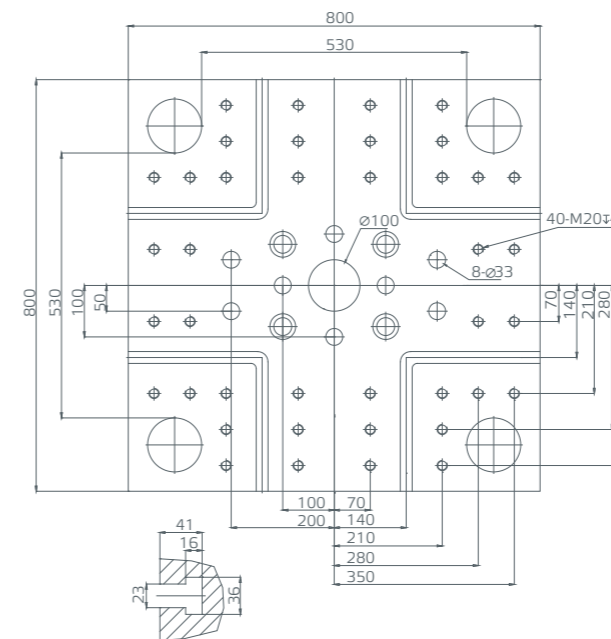

Robot installation dimension

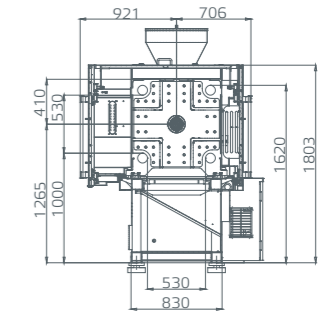

Robot fixed platen dimension

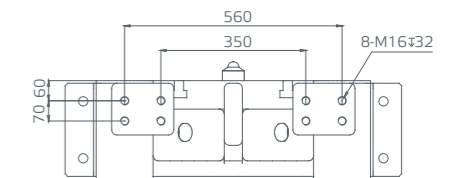

Feeding port dimensions

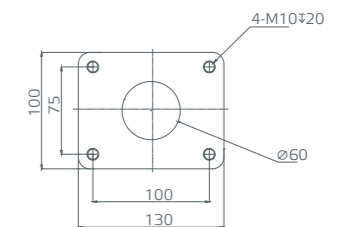

Clamping unit

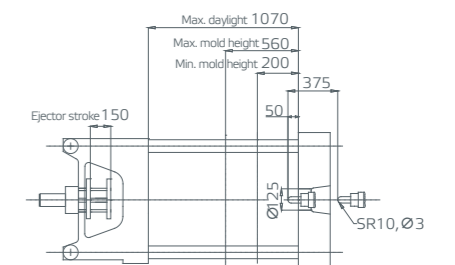

Unit:mm

NEO-T

Parameters

Clamping unit		NEO-T260		
Clamping force	kN	2600		
Clamping stroke	mm	550		
Space between tie bars	mm	610×570		
Max. mold height	mm	600		
Min. mold height	mm	220		
Ejector stroke	mm	160		
Ejector force	kN	67		
No. of ejector pins	piece	13		
Max. daylight	mm	1150		
Min. mold dimension	mm	427×427		
Platen dimensions (HxV)	mm	890×850		
Injection unit		i1100		
	Unit	A	B	C
Screw diameter	mm	50	55	60
Screw L/D ratio	L/D	22.0	20.0	18.3
Shot size (theoretical)	cm ³	522	632	752
Injection weight (PS)	g	475	571	684
Injection pressure	MPa	235.2	194.4	163.3
Injection rate into air	g/s	197	238	284
Screw speed	rpm	220		
Max. injection speed	mm/s	110		
Injection stroke	mm	266		
Others		i1100		
Max. pump pressure	MPa	17.5		
Pump motor power	kW	32		
Heater power	kW	16.0		
Hopper capacity	kg	50		
Oil tank volume	L	255		
Total machine weight	t	8.4		
Machine dimension (LxWxH)	m	5.45x1.63x2.20		

Remarks:

The bearing weight by moving platen is 2/3 of the maximum mold weight.

Theoretical capacity is the calculated volume of injection produced by the cross-sectional area of the screw/plunger and the injection stroke

The injection weight (PS) is the theoretical value derived from the injection volume and the typical melt density of polystyrene

The screw speed is the theoretical maximum screw speed.

Please inform us if you have requirement for engineering material like PVC, PMMA or some special requirement.

Due to continuous improvements, we reserve the right to modify any aspect of the specification without prior notice.

Front view of machine dimension

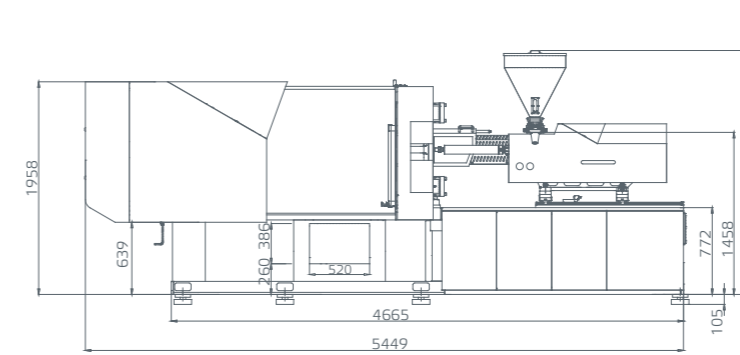

Top view of machine dimension

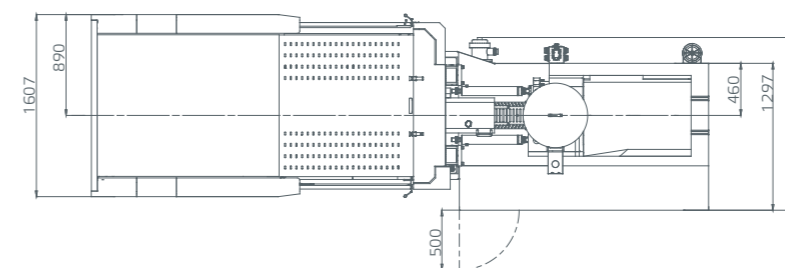

Moving platen dimension

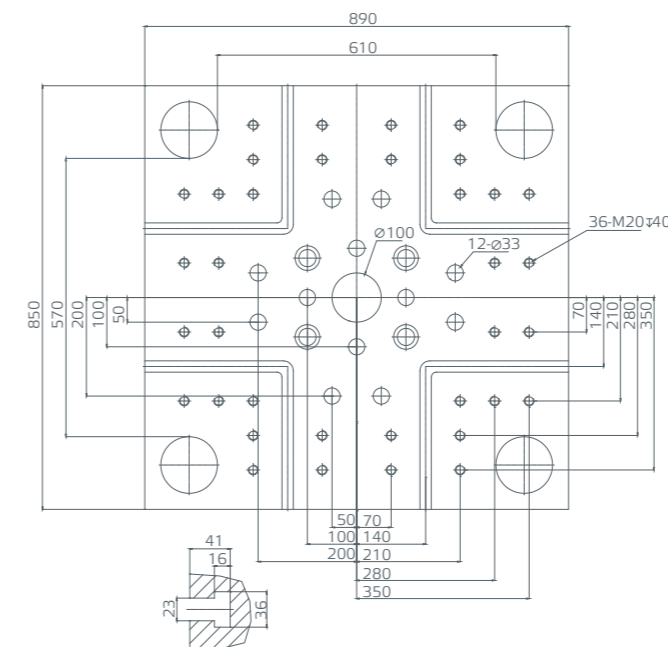

Robot installation dimension

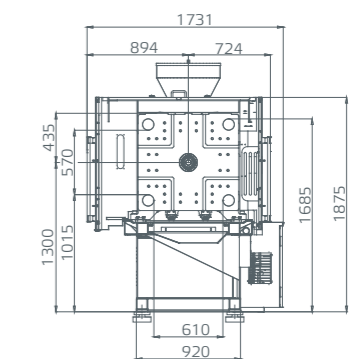

Robot fixed platen dimension

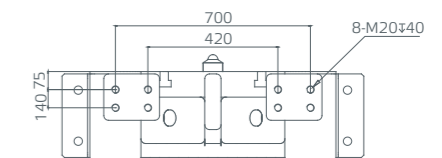

Feeding port dimensions

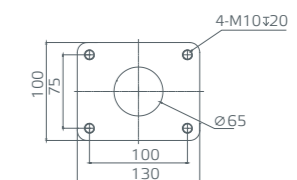

Clamping unit

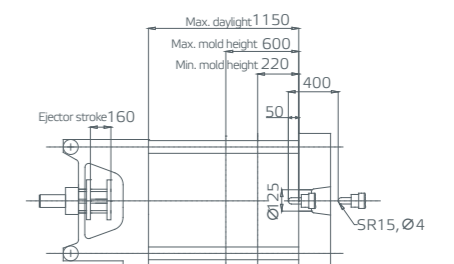

Unit:mm

NEO-T

Parameters

Clamping unit	Unit	NEO-T320		
Clamping force	kN	3200		
Clamping stroke	mm	650		
Space between tie bars	mm	710×670		
Max. mold height	mm	685		
Min. mold height	mm	250		
Ejector stroke	mm	160		
Ejector force	kN	67		
No. of ejector pins	piece	13		
Max. daylight	mm	1335		
Min. mold dimension	mm	497×497		
Platen dimensions (HxV)	mm	1035×1005		
Injection unit	Unit	i1900		
		A	B	C
Screw diameter	mm	60	65	70
Screw L/D ratio	L/D	21.7	20.0	18.6
Shot size (theoretical)	cm ³	845	992	1151
Injection weight (PS)	g	769	903	1047
Injection pressure	MPa	218.8	186.4	160.7
Injection rate into air	g/s	299	352	408
Screw speed	rpm	200		
Max. injection speed	mm/s	117		
Injection stroke	mm	299		
Others	Unit	i1900		
Max. pump pressure	MPa	17.5		
Pump motor power	kW	51		
Heater power	kW	25.0		
Hopper capacity	kg	50		
Oil tank volume	L	445		
Total machine weight	t	12.1		
Machine dimension (LxWxH)	m	6.56x1.89x2.31		

Remarks:

The bearing weight by moving platen is 2/3 of the maximum mold weight.

Theoretical capacity is the calculated volume of injection produced by the cross-sectional area of the screw/plunger and the injection stroke

The injection weight (PS) is the theoretical value derived from the injection volume and the typical melt density of polystyrene

The screw speed is the theoretical maximum screw speed.

Please inform us if you have requirement for engineering material like PVC, PMMA or some special requirement.

Due to continuous improvements, we reserve the right to modify any aspect of the specification without prior notice.

Front view of machine dimension

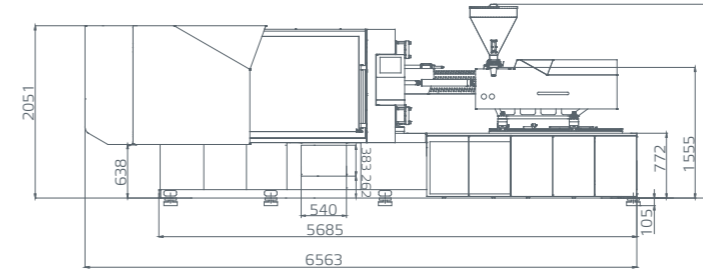

Top view of machine dimension

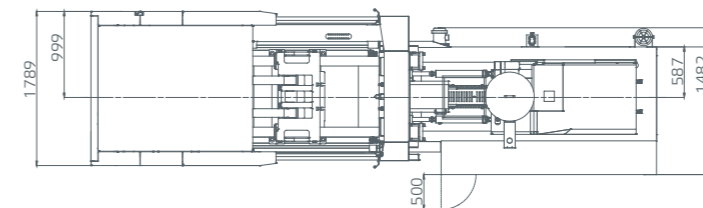

Moving platen dimension

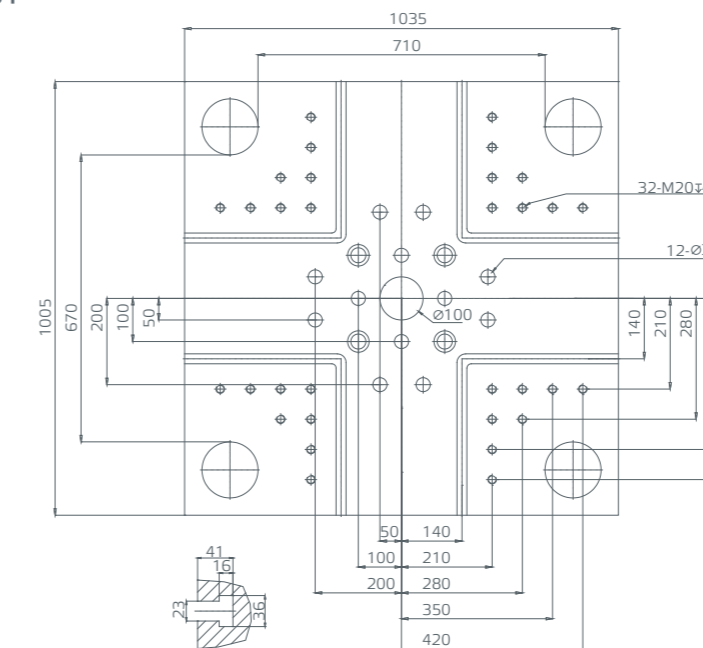

Robot installation dimension

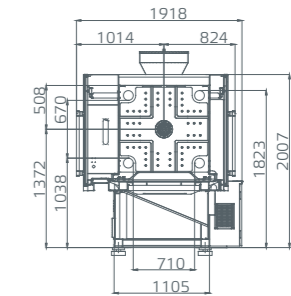

Robot fixed platen dimension

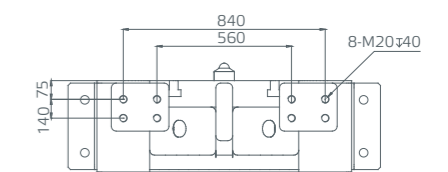

Feeding port dimensions

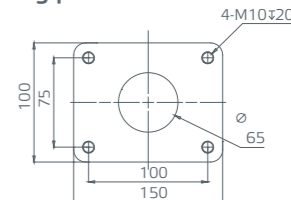

Clamping unit

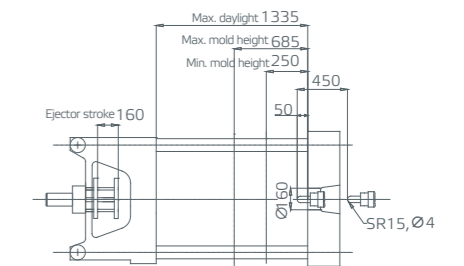

Unit:mm

NEO-T

Parameters

Clamping unit		NEO-T400		
Clamping force	kN	4000		
Clamping stroke	mm	720		
Space between tie bars	mm	760×710		
Max. mold height	mm	750		
Min. mold height	mm	280		
Ejector stroke	mm	200		
Ejector force	kN	124		
No. of ejector pins	piece	13		
Max. daylight	mm	1470		
Min. mold dimension	mm	532×532		
Platen dimensions (HxV)	mm	1100×1050		
Injection unit		i2500		
	Unit	A	B	C
Screw diameter	mm	65	70	75
Screw L/D ratio	L/D	23.7	22.0	20.5
Shot size (theoretical)	cm ³	1161	1347	1546
Injection weight (PS)	g	1057	1226	1407
Injection pressure	MPa	215.4	185.7	161.8
Injection rate into air	g/s	375	434	499
Screw speed	rpm	185		
Max. injection speed	mm/s	124		
Injection stroke	mm	350		
Others		i2500		
Max. pump pressure	MPa	17.5		
Pump motor power	kW	61		
Heater power	kW	26.0		
Hopper capacity	kg	50		
Oil tank volume	L	535		
Total machine weight	t	15.5		
Machine dimension (LxWxH)	m	7.40×2.11×2.46		

Remarks:

The bearing weight by moving platen is 2/3 of the maximum mold weight.

Theoretical capacity is the calculated volume of injection produced by the cross-sectional area of the screw/plunger and the injection stroke

The injection weight (PS) is the theoretical value derived from the injection volume and the typical melt density of polystyrene

The screw speed is the theoretical maximum screw speed.

Please inform us if you have requirement for engineering material like PVC, PMMA or some special requirement.

Due to continuous improvements, we reserve the right to modify any aspect of the specification without prior notice.

Front view of machine dimension

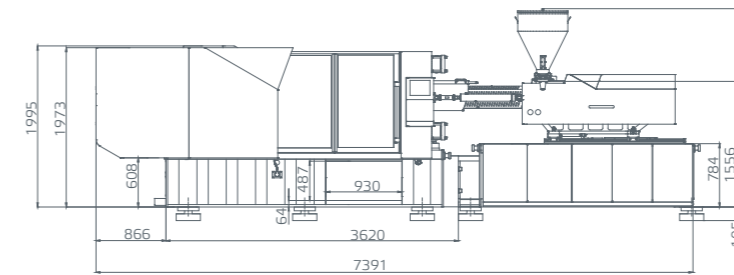

Top view of machine dimension

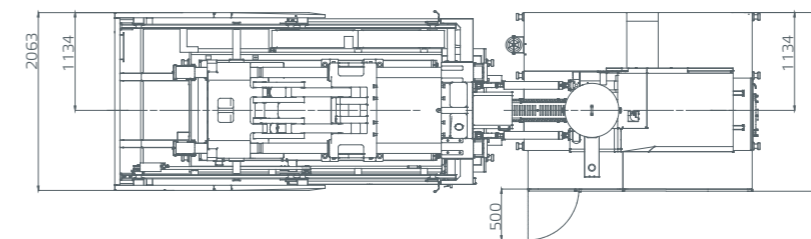

Moving platen dimension

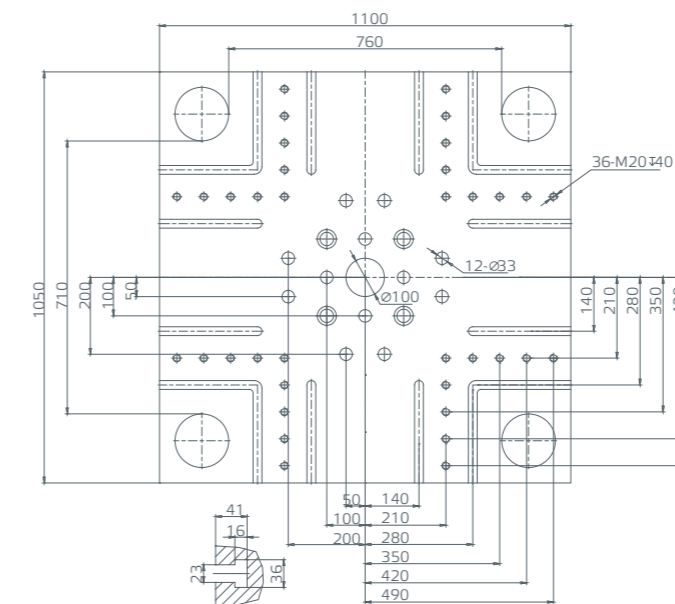

Robot installation dimension

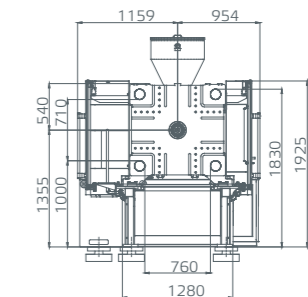

Robot fixed platen dimension

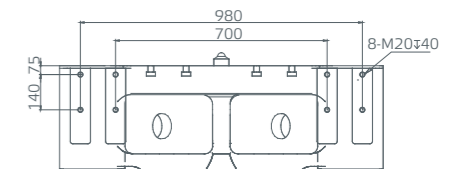

Feeding port dimensions

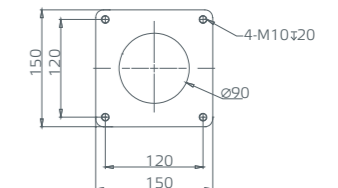

Clamping unit

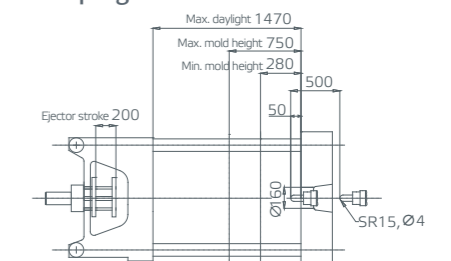

Unit:mm

NEO-T

Parameters

Clamping unit		NEO-T500		
Clamping force	kN	5000		
Clamping stroke	mm	800		
Space between tie bars	mm	820×820		
Max. mold height	mm	800		
Min. mold height	mm	320		
Ejector stroke	mm	200		
Ejector force	kN	124		
No. of ejector pins	piece	17		
Max. daylight	mm	1600		
Min. mold dimension	mm	574x574		
Platen dimensions (HxV)	mm	1205x1205		
Injection unit		i3800		
	Unit	A	B	C
Screw diameter	mm	75	80	85
Screw L/D ratio	L/D	23.5	22.0	20.7
Shot size (theoretical)	cm ³	1785	2031	2293
Injection weight (PS)	g	1624	1848	2086
Injection pressure	MPa	205.3	180.5	159.9
Injection rate into air	g/s	452	514	580
Screw speed	rpm	165		
Max. injection speed	mm/s	112		
Injection stroke	mm	404		
Others		i3800		
Max. pump pressure	MPa	17.5		
Pump motor power	kW	32+32		
Heater power	kW	37.0		
Hopper capacity	kg	50		
Oil tank volume	L	590		
Total machine weight	t	19.8		
Machine dimension (LxWxH)	m	8.1x2.17x2.65		

Remarks:

The bearing weight by moving platen is 2/3 of the maximum mold weight.

Theoretical capacity is the calculated volume of injection produced by the cross-sectional area of the screw/plunger and the injection stroke

The injection weight (PS) is the theoretical value derived from the injection volume and the typical melt density of polystyrene

The screw speed is the theoretical maximum screw speed.

Please inform us if you have requirement for engineering material like PVC, PMMA or some special requirement.

Due to continuous improvements, we reserve the right to modify any aspect of the specification without prior notice.

Front view of machine dimension

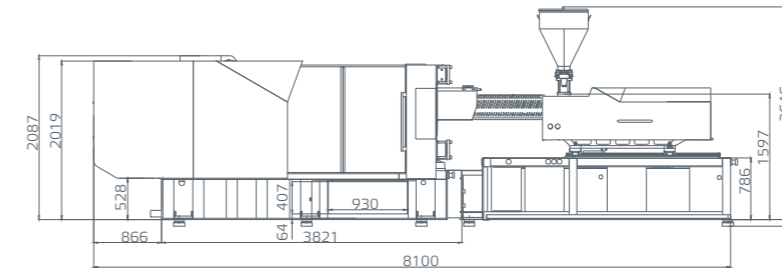

Top view of machine dimension

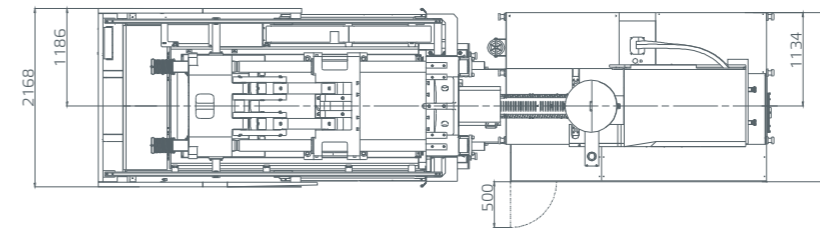

Moving platen dimension

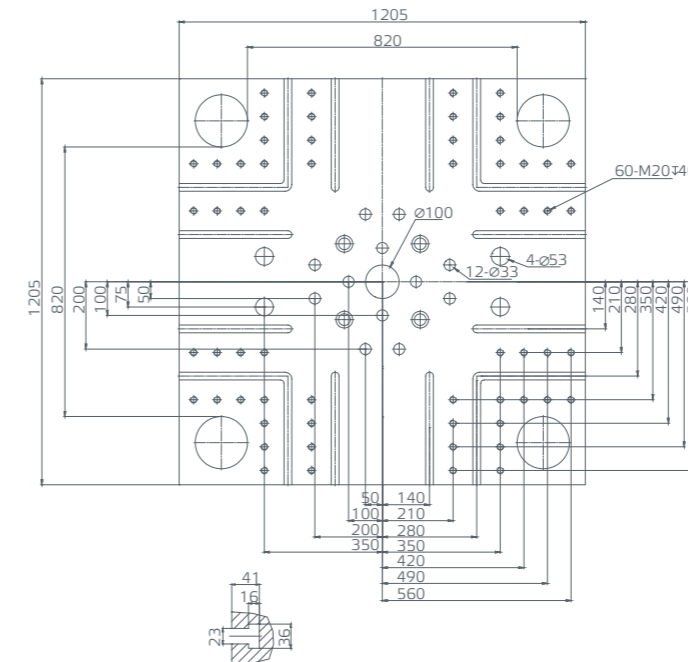

Robot installation dimension

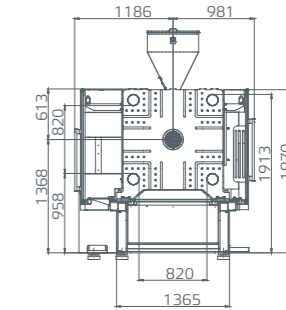

Robot fixed platen dimension

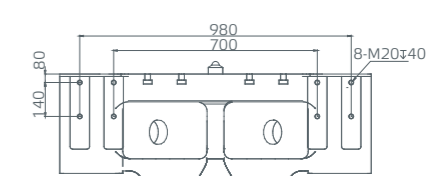

Feeding port dimensions

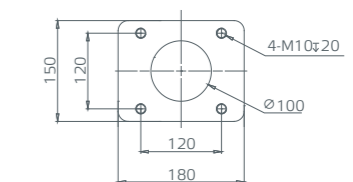

Clamping unit

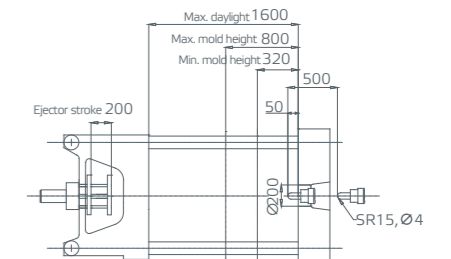

Unit:mm

Components & functions list

For clamping

Function description / Clamping unit	NEO-T90-NEO-T500	Function description / Injection unit	i380-i3800
High rigidity 5 points-doubt toggle structure	●	Standard nitriding screw and barrel	●
Screw platen	○	Specialized screw and barrel	○
T-slot platen+Screw platen	●	Double injection cylinder structure	●
Platen Euromap 2 size	○	Double carriage cylinder injection unit	●
Locating ring on moving platen	●	Double stage linear guid injection structure	●
Mechanical, electric and hydraulic safety	●	Carriage transducer	●
Automatic central lubricating system for toggle, platen shoe and bush	●	Screw rotation speed display	●
Central lubrication system for mould adjust	●	Proportional injection valve	○
Various eject function	●	Hydraulic plasticizing	●
Low pressure mold protection	●	Proportional back pressure control	●
One button automatic mold adjustment	●	Cold start protection	●
Self-lock mold adjust motor	●	Material self-cleaning function	●
Compulsory ejector-back function	●	Temperature monitor for feeding throat	○
Quick change of central eject pin	●	Feeding throat temperature close loop control	○
Transducer on moving platen	●	Barrel overheating protection	●
Adjustable supporting feet for moving platen	●	Nozzle cover	●
High rigidity sliding belt for moving platen	●	Self-lock valve for carriage	●
Euromap 18 robot interface	●	Swivel injection unit	●
Mechanical position limitation for moving platen	○	Manual central lubricating device for carriage	●
Fast connecting water regulator	●	Mica heating band	●
2 groups of core pulling valve	●	Ceramic heating band	○
2 groups of air blaster valve	●	Nano infrared heating band	○
Glass water regulation	○	Wheel sliding hopper	●
Proportional mold open/close valve	○	Stainless hopper	●

For injection

For electric

For hydraulic

Function description / Injection unit	i380-i3800	Function description / Clamping unit	NEO-T90-NEO-T500
Techmation controller 12 screen	●	Fast response servo system	●
KEBA controller	○	Upgrade screw motor	○
Real time running monitoring function	●	Bi-pass oil filter	●
Production monitoring function	●	Hydraulic safety device	●
Alarm display	●	Carriage self lock valve	●
Time/Position control for the injection to pressure hold	●	Self lock motor	●
Pressure control from injection to pressure hold	○	Mold close control valve	●
I/O monitoring display	●	Low pressure mold protection function	●
Tri-color alarm	●	Mold open shock mitigation device	●
Motor overload protection	●	Injection pressure relief device	●
Emergency stop on front/rear door	●	Pressure control for Injection to hold on pressure	○
380V/16A 5 pin socket *1	○	Programmable injection sequence	○
380V/16A 5 pin socket *2 220V/16A 3 pin socket *1	●	Independent oil tank	●
380V/32A 5 pin socket *2 380V/16A 5 pin socket *1 220V/16A 3 pin socket *1	○	Cooling water valve	○
Transformer for servomotor system	○	Non-welding hydraulic pipe	●
Euromap 12 robot interface	○	Temperature monitoring	●
Euromap 67 robot interface	○	Oil level alarm	●
Euromap 13 core pulling interface	○	Oil self-suction filter	●
Double protection for heating	●	Protective link for hoses	●
Safety relay monitoring	●	Proportional injection valve	○
SSR heating control	●	Injection servo valve	○
Network centralized control system	○	Proportional valve for mould open/ close	○
Instant power consumption display	○	2 groups of core pulling	●
Instant clamping force display	○	2 groups of air balster	●

For other

Function description / Other	NEO-T90-NEO-T320	NEO-T400-NEO-T500
Standard tederic color	●	●
Leveling pad	●	●
Spare parts, regular tools, mold clasper, extended nozzle, operation manual	●	●
Robot	○	○
Magnetic grate	○	○
Chiller	○	○
Mold temperature controller	○	○
Dehumidifier	○	○
Auto loader	○	○
Fumigation wood frame	○	○
Hydraulic oil	○	○
Product platform		○

● Standard ○ Optional

● Standard ○ Optional